

Description

The HRL incremental encoder fits onto an existing shaft and converts shaft rotation into square wave pulses to provide an accurate and reliable means of digitizing position, rate, or length of travel. The number of pulses per shaft revolution is determined by setting configuration switches.

Model ID

HRL - P64AJ /

Shaft diameter:
1 = 1"
 M25 = 25mm
 (Inquire for others)

Supply voltage:
 5 or 8-30

Output Circuit:
 Push/Pull is standard
 C = Open collector

Short lead time options are underlined.

Installation

- Slide HRL onto shaft.
- Fasten flexible mounting bracket (MB-FB1) to frame, or use other means to prevent rotation.
- Tighten HRL shaft set screws.
- Attach the cable leads to the control device (e.g. PLC) ensuring that the power supply meets specifications.
- Set the configuration switches (*can be changed at any time*).
- Attach the cable to the encoder.

Dimensions

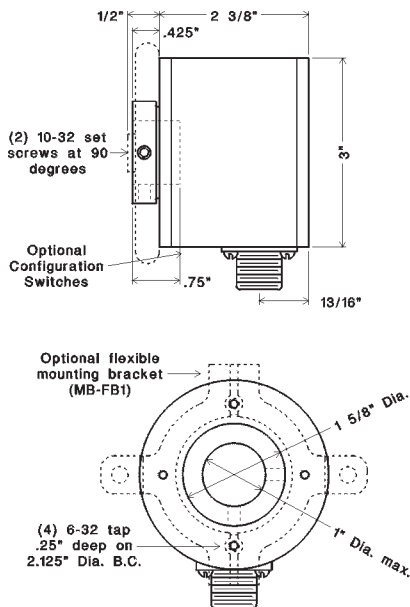

Electrical

Supply Voltage (V_{IN}): (see Model ID)

- $5 \pm 5\%$ vdc
- 8 to 30 vdc

Output circuit: (See fig. 2 and Model ID)

- Push/Pull
- Combined sourcing/sinking output
- Open collector
- NPN Open collector sinking output ($V_{CC}=30$ vdc maximum)

Output Protection: ESD and Short Circuit

Supply Current: 50ma maximum (no load)

Output Current (I_O): 50ma max source/sink

Operating temperature: -25° to $+85^\circ$ C

Maximum operating speed: 2,500 rpm

Outputs

Pulses per Revolution Output: Selectable by setting switches 1 to 6 (figure 1). "Low" when power is initially applied.

- Output Waveform:** 50/50 squarewave
- **Pulse On-Off Ratio:** $50\% \pm 10\%$
 - **Pulse Interval Jitter:** $\pm 10\%$
 - **Pulse rise time:** 2 μ sec (max)
 - **Pulse fall time:** 5 μ sec (max)
 - **Voltage (high):** $V_{in}-2.5$ vdc (min)
 - **Voltage (low):** 1.5 vdc (max)

(600 rpm, $V_{IN}=24$ vdc, $10ma < I_O < 50ma$, 25° C)

Anti-jitter Feature: Increases pulse output hysteresis to $1/2$ of a pulse width, eliminating the effects of mechanical vibration and the possible dither that results in false output pulses.

Electrical Connections

Pin No.	Function	Wire Color
A	Supply Voltage	Red
B	Common	Black
D	Pulse output	White
D	No connection	—
E	no connection	—
—	Case Ground	Plain

Specifications

Mechanical

Weight: 16.8 oz. (477 grams)

Shaft Loading: Radial: 25 lb. (2.5 kg.) max.
 Axial: 10 lb. (1 kg.) max.

Bearing Life (L_{10}): 36×10^6 /RPM = hours

Materials:

- Case: Aluminum, anodized
- Shaft: Aluminum
- Switch Access Door: Plastic

Connector: 97-MS3102A-14S-5P (5-pin)

Accessories

Cable Assembly (C5-3-10): 10 ft. (3m) of 3 conductor, shielded cable with mating connector. Other lengths are available.

CE mark requires Photocraft cable, and surge protection if the cable exceeds 100' (30m) or leaves the building.

Flexible Mounting Bracket (MB-FB1): flexible stainless steel that allows for axial and angular shaft misalignment.

Configuration Switches

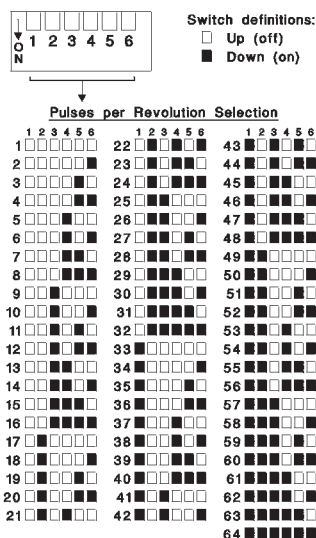

Figure 1 - Configuration Switches

OVER 25 YEARS OF
 MATERIAL HANDLING AND
 INDUSTRIAL EXPERIENCE

HOTOCRAFT INC

602 E. North Street
 Elburn, IL 60119, USA
 www.photocraftencoders.com

630-365-7148
 Fax: 630-365-7149

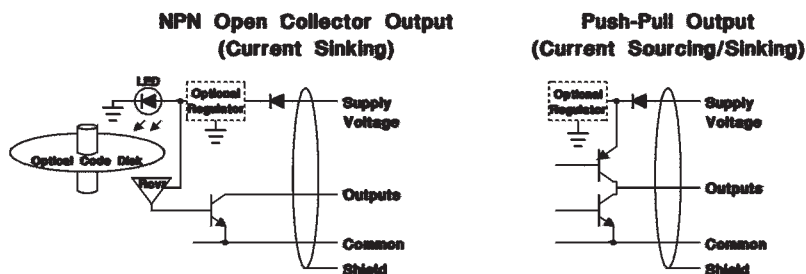

Figure 2 - Output Circuits